

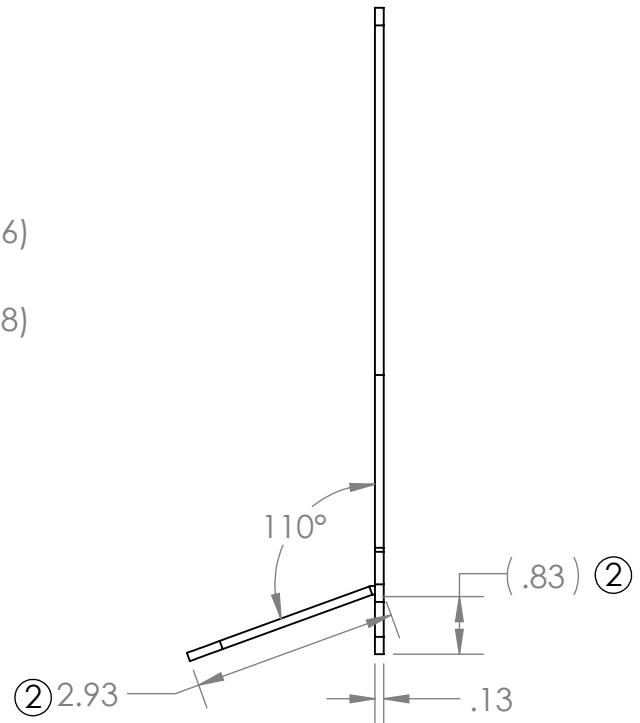

REVISION HISTORY			
REV.	DESCRIPTION	DATE	DRAWN BY
1	ORIGINAL PRINT	4/2/2025	E. SCIME
2	ADDED ADDITIONAL DIMENSIONS	4/23/2025	E. SCIME
3	UPDATED DRAWING SCALE & OUTER GEOMETRY	5/1/2025	E. SCIME

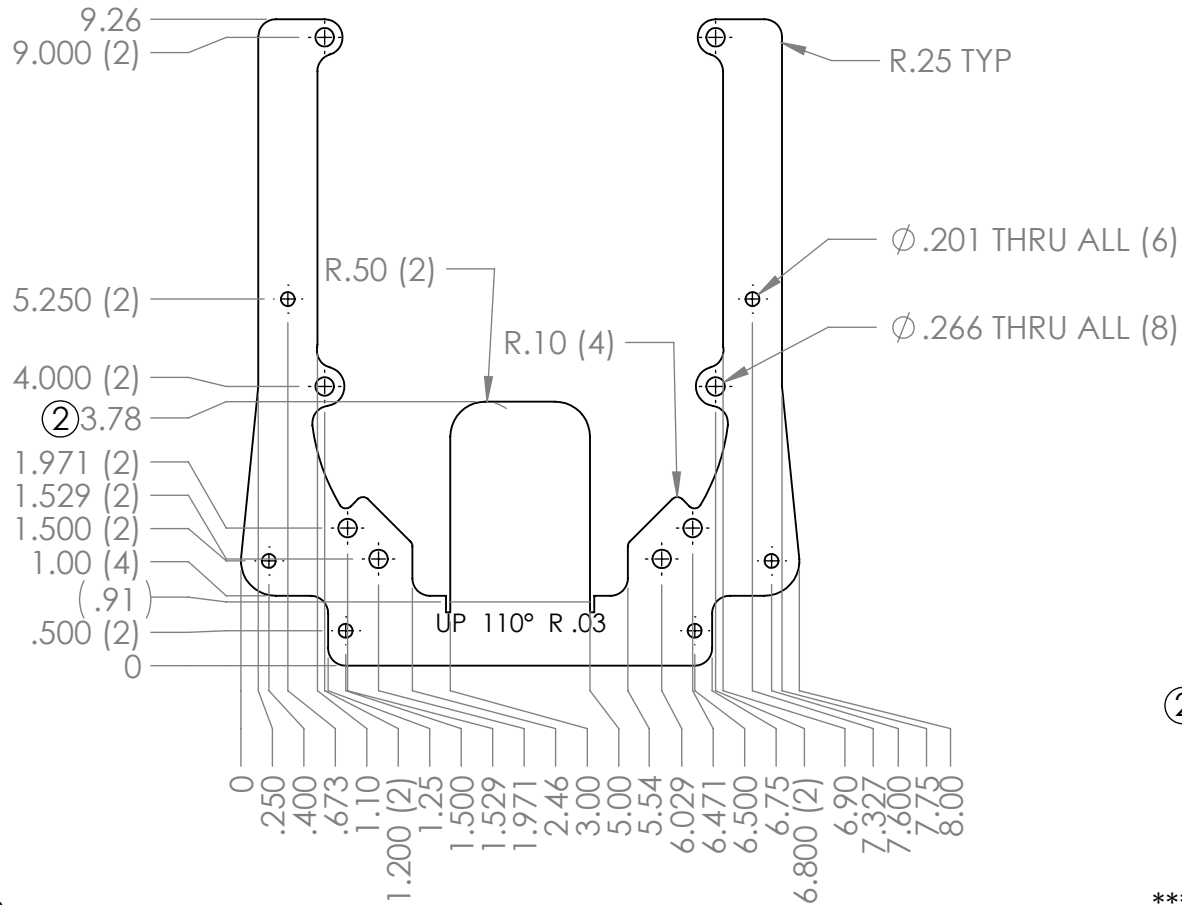

*** SEE CAD FOR ADDITIONAL TOOLPATH INFO***

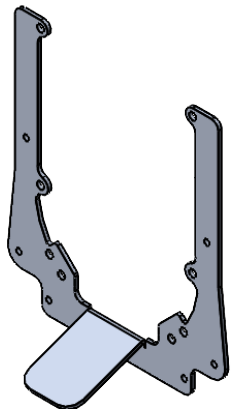

UNLESS OTHERWISE SPECIFIED:		COMMENTS:					
DIMENSIONS ARE IN INCHES		DUAL DIMENSIONS ARE IN MILLIMETERS.					TITLE:
TOLERANCES:		BREAK ALL SHARP EDGES.		RAMP END BRACKET			
FRACTIONAL	±1/16			SIZE	DWG. NO.	REV	
ANGULAR: MACH	±1°			A	am-5727	3	
ANGULAR: BEND	±5°			SCALE: 1:2.75		SHEET 1 OF 1	
ONE PLACE DECIMAL	±0.1						
TWO PLACE DECIMAL	±0.01	MATERIAL					
THREE PLACE DECIMAL	±0.005	5052 AL					
FOUR PLACE DECIMAL	±0.0005	FINISH					
DO NOT SCALE DRAWING		DEBURRED					
		CHECKED		NAME	DATE		
		ENG APPR.		PY	5/1/25		
		MFG APPR.					
		Q.A.					